

BK Series

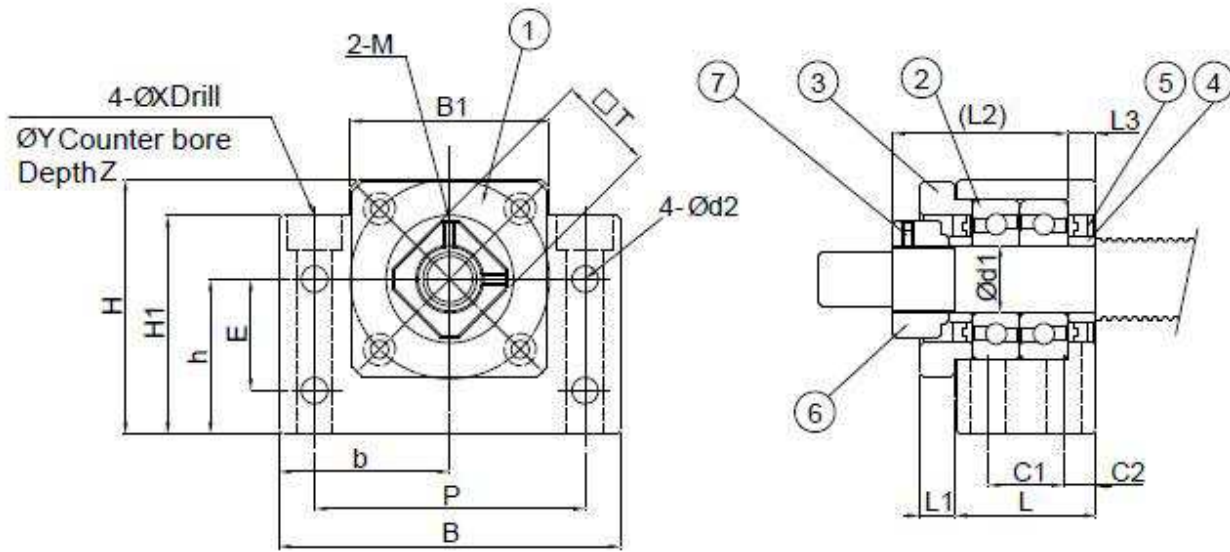

Part No.	Part name	Qty
1	Housing	1
2	Bearing	1 set
3	Holding lid	1
4	Collar	2
5	Seal	2
6	Set screw	1
7	Hexagonal socket-head setscrew with set piece	2



Specification	Main dimensions (mm)																				Weight (kg)	
	d1	L	L1	L2	L3	B	H	b [Note 1]	h [Note 1]	B1	H1	E	P	C1	C2	d2	X	Y	Z	M		T
BK10	10	25	5	29.5	5	60	39	30	22	34	32.5	15	46	13	6	5.5	6.6	10.8	5	M3	16	0.4
BK12	12	25	5	29.5	5	60	43	30	25	34	32.5	18	46	13	6	5.5	6.6	10.8	1.5	M4	19	0.45
BK15	15	27	6	32	6	70	48	35	28	40	38	18	54	15	6	5.5	6.6	11	6.5	M4	22	0.6
BK17	17	35	9	44	7	86	64	43	39	50	55	28	68	19	8	6.6	9	14	8.5	M4	24	1.3
BK20	20	35	8	43	8	88	60	44	34	52	50	22	70	19	8	6.6	9	14	8.5	M4	30	1.3
BK25	25	42	12	54	9	106	80	53	48	64	70	33	85	22	10	9	11	17	11	M6	35	2.4
BK30	30	45	14	61	9	128	89	64	51	76	78	33	102	23	11	11	14	20	13	M6	40	3.4
BK35	35	50	14	67	12	140	96	70	52	88	79	35	114	26	12	11	14	20	13	M6	50	4.4
BK40	40	61	18	76	15	160	110	80	60	100	90	37	130	33	14	14	18	26	17.5	M6	50	6.8

BF Series

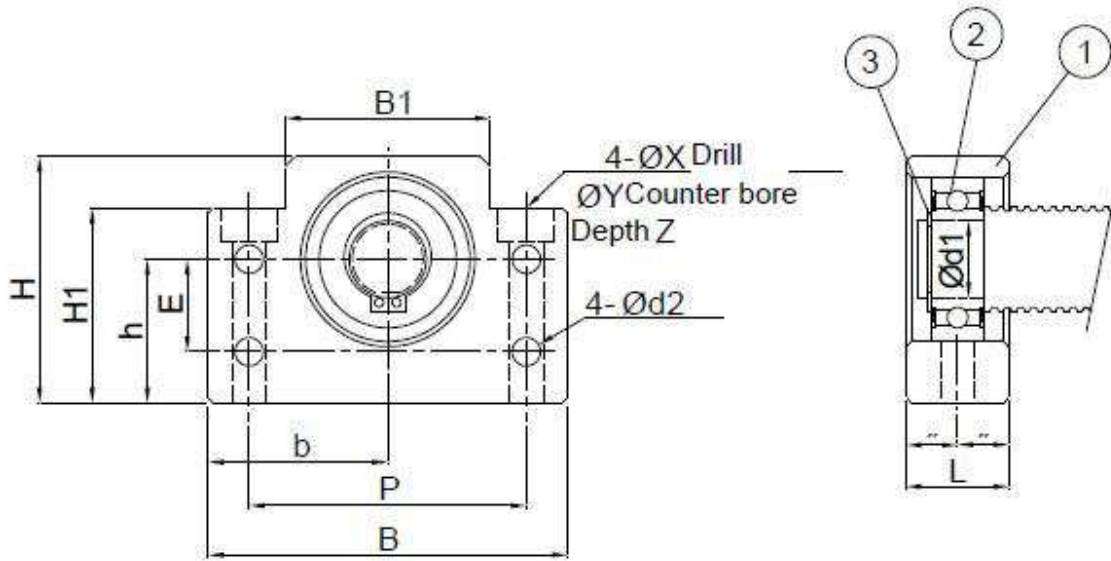

Part No.	Part name	Qty
1	Housing	1
2	Bearing	1
3	Snap ring	1

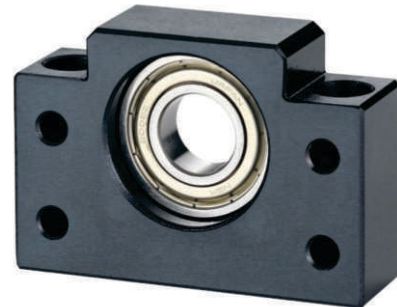

BF25	25	30	106	80	53	48	64	70	33	85	9	11	17	11	6205ZZ	S25	1.45
BF30	30	32	128	89	64	51	76	78	33	102	11	14	20	13	6206ZZ	S30	1.95
BF35	35	32	140	96	70	52	88	79	35	114	11	14	20	13	6207ZZ	S35	2.25
BF40	40	37	160	110	80	60	100	90	37	130	14	18	26	17.5	6208ZZ	S40	3.3
BF15	15	20	70	48	35	28	40	38	18	54	5.5	6.6	11	6.5	6002ZZ	S15	0.4
BF17	17	23	86	64	43	39	50	55	28	68	6.6	9	14	8.5	6203ZZ	S17	0.75
BF20	20	26	88	60	44	34	52	50	22	70	6.6	9	14	8.5	6004ZZ	S20	0.77

FK Series

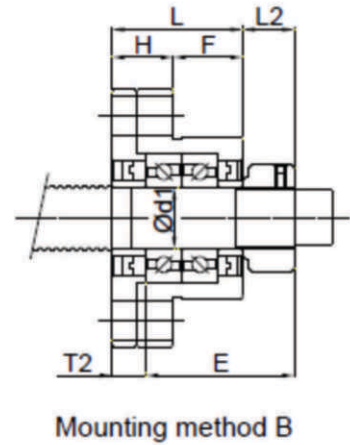
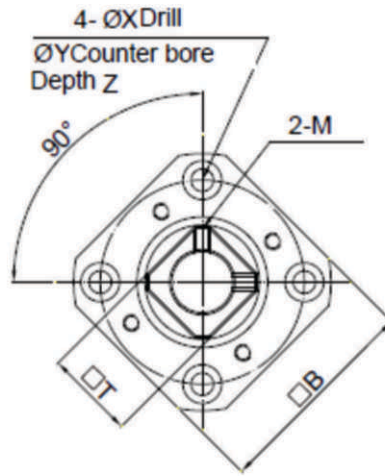
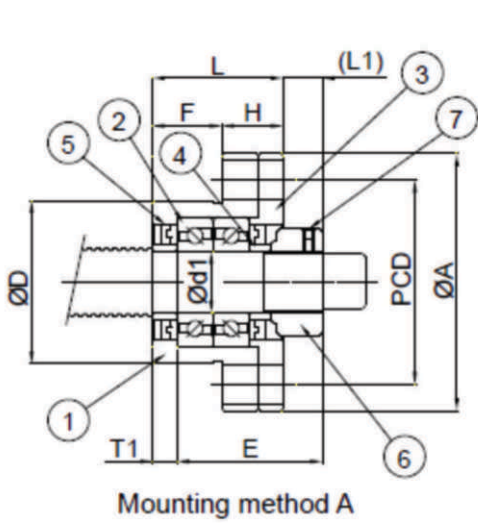

Part No.	Part name	Qty
1	Housing	1
2	Bearing	1 set
3	Holding lid	1
4	Collar	2
5	Seal	2
6	Set screw	1
7	Hexagonal socket-head setscrew with set piece	2



Specification	Main dimensions (mm)																		
	d1	L	H	F	E	D (Note 1)	A	PCD	B	Mounting method A		Mounting method B		X	Y	Z	M	T	Weight (kg)
										L1	T1	L2	T2						
FK05	5	16.5	6	10.5	18.5	20	34	26	26	5.5	3.5	5	3	3.4	6.5	4	M3	11	0.1
FK06	6	20	7	13	22	22	36	28	28	5.5	3.5	6.5	4.5	3.4	6.5	4	M3	11	0.1
FK08	8	23	9	14	26	28	43	35	35	7	4	8	5	3.4	6.5	4	M3	14	0.16
FK10	10	27	10	17	29.5	34	52	42	42	7.5	5	8.5	6	4.5	8	5	M3	16	0.25
FK12	12	27	10	17	29.5	36	54	44	44	7.5	5	8.5	6	4.5	8	5	M4	19	0.26
FK15	15	32	15	17	36	40	63	50	52	10	6	12	8	5.5	9.5	6	M4	22	0.4
FK17	17	45	22	23	47	50	77	62	61	11	9	14	12	6.6	11	10	M4	24	0.85
FK20	20	52	22	30	50	57	85	70	68	8	10	12	14	6.6	11	10	M4	30	1.2
FK25	25	57	27	30	60	63	98	80	79	13	10	20	17	9	15	13	M6	35	1.6
FK30	30	62	30	32	61	75	117	95	93	11	12	17	18	11	17.5	15	M6	40	2.38

FF Series

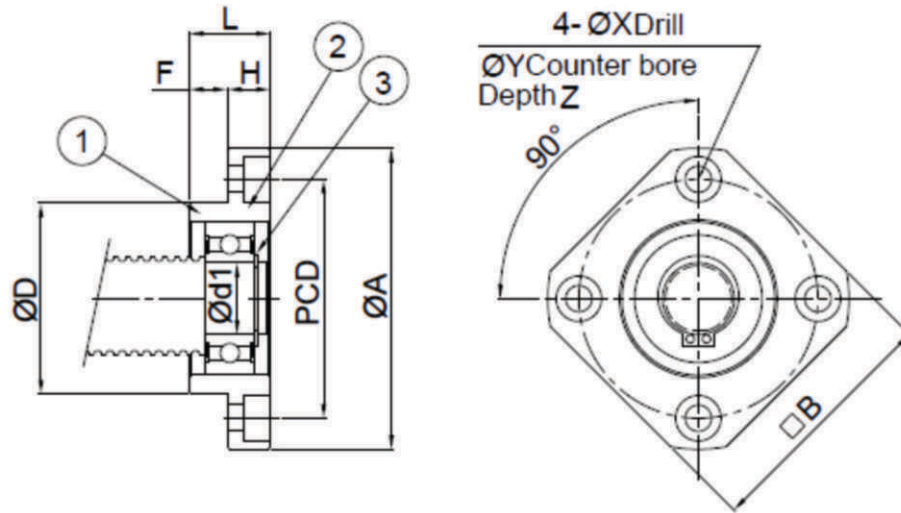

Part No.	Part name	Qty
1	Housing	1
2	Bearing	1
3	Snap ring	1

Specification	Main dimensions (mm)													
	d1	L	H	F	D (Note 1)	A	PCD	B	X	Y	Z	Bearing	Snap ring	Weight (kg)
FF06	6	10	6	4	22	36	28	28	3.4	6.5	4	606ZZ	S06	0.08
FF10	8	12	7	5	28	43	35	35	3.4	6.5	4	608ZZ	S08	0.1
FF12	10	15	7	8	34	52	42	42	4.5	8	4	6000ZZ	S10	0.15
FF15	15	17	9	8	40	63	50	52	5.5	9.5	5.5	6002ZZ	S15	0.22
FF17	17	20	11	9	50	77	62	61	6.6	11	6.5	6203ZZ	S17	0.35
FF20	20	20	11	9	57	85	70	68	6.6	11	6.5	6204ZZ	S20	0.45
FF25	25	24	14	10	63	98	80	79	9	14	8.5	6205ZZ	S25	0.66
FF30	30	27	18	9	75	117	95	93	11	17	11	6206ZZ	S30	1.05